

**Product Data Sheet****Standard Features:**

- Carbon steel frame with 304 stainless steel extension tube
  - Aluminum gearbox housing
- Stroke lengths: 4", 6", 8", 10", 12", 18", 24", [other stroke lengths available]
- Input voltage: 12VDC, 24VDC, (48VDC – special order)
- Standard gear ratio: 10:1 [5:1, 20:1, 30:1, 40:1 gear ratios available]
- Dynamic load range: 674 lbs. [3,000 Newtons] est. -to- 2,248 lbs. [10,000 Newtons]
- Maximum static load: 3,057 lbs. [13,600 Newtons]
- Maximum current draw (at full load): 28.7 Amps @ 12 VDC
- Speed at no load: 0.4 in/sec [9.6 mm/sec] -to- 3.2 in/sec [80.1 mm/sec]
- Speed at full load: 0.3 in/sec [8.5 mm/sec] -to- 2.4 in/sec [60.5 mm/sec]
- Overload clutch
- Ball screw drive
- Mounting hole diameter (both ends): 1/2" [13mm]
- Duty cycle: 25% or 2 min continuous operation in 8 min. (5:1, 10:1, 20:1)
- Duty cycle: 10% or 1 min continuous operation in 10 min. (30:1, 40:1)
- Working temperature: -13F [-25C] to +149F [+65C]
- IP rating: IP65, (IP69K – special order)

**Accessories:**

- Mounting brackets
- Direction reversing switches
- Direction reversing relays
- Direction reversing wireless controllers

**Dimensions**

**Standard (without Limit Switches or Potentiometer)**

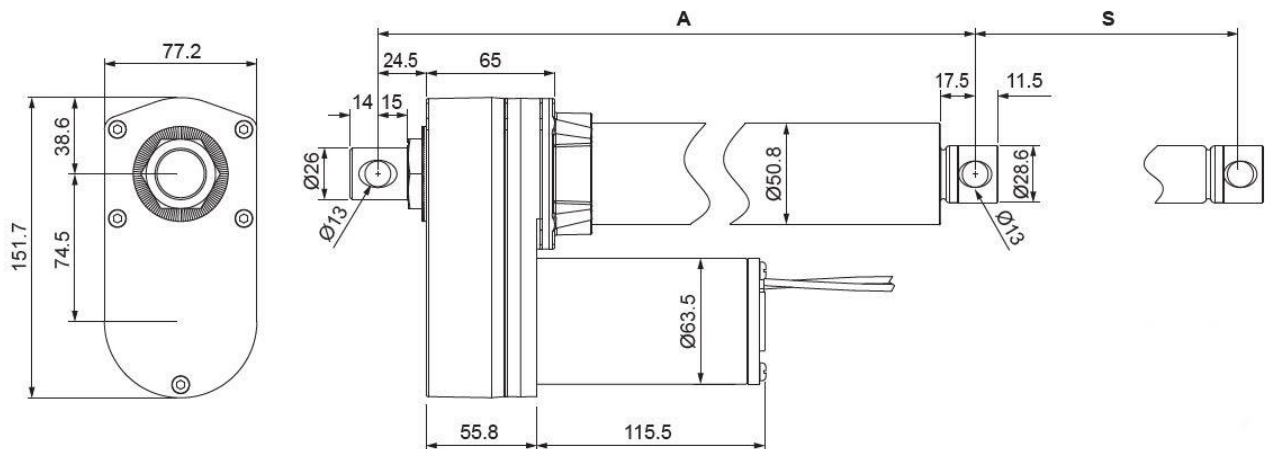

Nominal Stroke	4"		6"		8"		10"		12"		18"		24"	
	in	mm	in	mm	in	mm	in	mm	in	mm	in	mm	in	mm
Actual Stroke (S)	4.0	102	6.0	153	8.0	203	10.0	254	12.0	305	18.0	457	24.0	610
Retracted Length (A)	11.9	302	13.9	353	15.9	404	17.9	455	19.9	506	28.9	735	35.0	888
Extended Length	15.9	404	19.9	506	23.9	607	27.9	709	31.9	811	46.9	1192	59.0	1498

Tolerance: ±5mm

**Dimensions  
With Potentiometer Only**

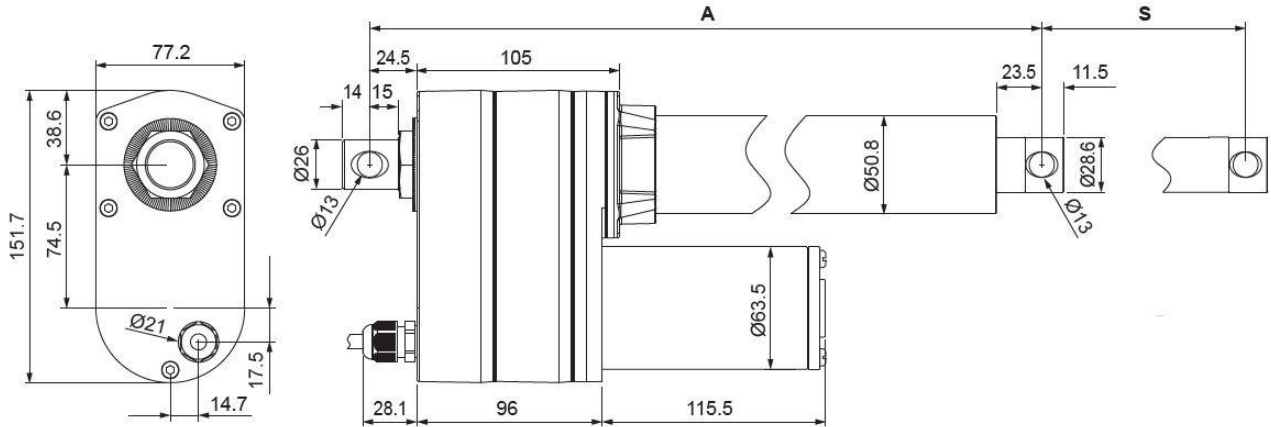

Nominal Stroke	4"		6"		8"		10"		12"		18"		24"	
	in	mm	in	mm	in	mm	in	mm	in	mm	in	mm	in	mm
Actual Stroke (S)	4.0	102	6.0	153	8.0	203	10.0	254	12.0	305	18.0	457	24.0	610
Retracted Length (A)	13.5	342	15.5	393	17.5	444	19.5	495	21.5	546	30.5	775	36.5	928
Extended Length	17.5	444	21.5	546	25.5	647	29.5	749	33.5	851	48.5	1232	60.6	1538

Tolerance  $\pm 5$ mm

**Dimensions  
With Only Limit Switches or Limit Switches and Potentiometer**

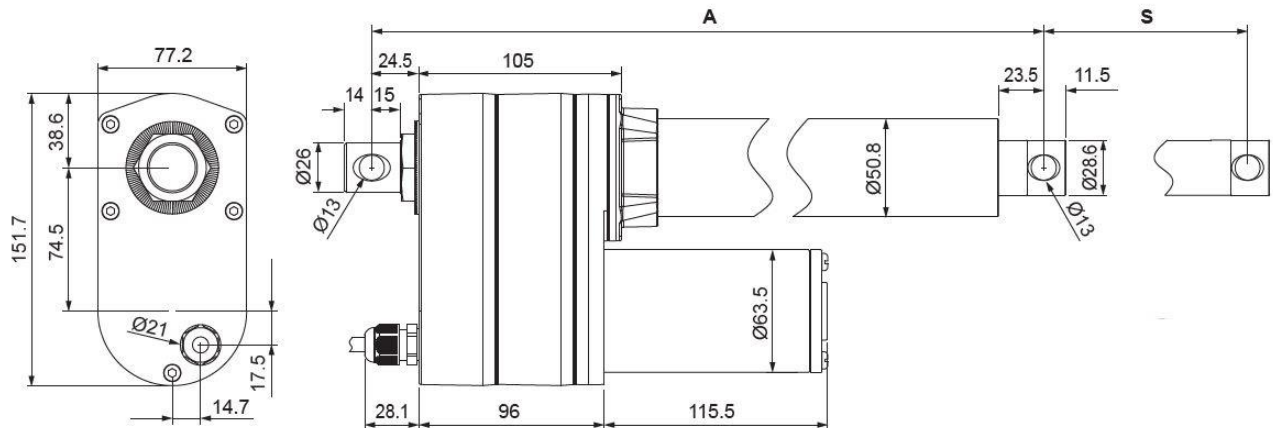

Nominal Stroke	4"		6"		8"		10"		12"		18"		24"	
	in	mm	in	mm	in	mm	in	mm	in	mm	in	mm	in	mm
Actual Stroke (S)	4.0	102	6.0	153	8.0	203	10.0	254	12.0	305	18.0	457	24.0	610
Retracted Length (A)	15.7	399	17.7	450	19.7	501	21.7	552	26.8	680	32.8	832	38.8	985
Extended Length	19.7	501	23.7	603	27.7	704	31.7	806	38.8	985	50.7	1289	62.8	1595

Tolerance: ±7mm

**Performance Data**

**12 volt**

Gear Ratio	Max Load/Dynamic		Typical Speed/No Load		Typical Speed/Max Load	
	Lbs. [US]	Newtons	inches/sec	mm/sec	inches/sec	mm/sec
5:1	674 est.	3000 est.	3.0	76.1	1.7	43.6
10:1	1012	4500	1.5	38.0	1.1	28.0
20:1	1461	6500	0.9 est.	22.1 est.	0.6 est.	15 est.
30:1	1798	8000	0.6 est.	14 est.	0.4 est.	11 est.
40:1	2248	10000	0.4	9.6	0.3	8.5

est. = estimated value

**24 volt**

Gear Ratio	Max Load/Dynamic		Typical Speed/No Load		Typical Speed/Max Load	
	Lbs. [US]	Newtons	inches/sec	mm/sec	inches/sec	mm/sec
5:1	674 est.	3000 est.	3.1	79.8	2.2	55.0
10:1	1012	4500	NDA	NDA	NDA	NDA
20:1	1461	6500	0.8	20.1	0.7	17.4
30:1	1798	8000	0.6 est.	14 est.	0.4 est.	11 est.
40:1	2248	10000	0.4	9.7	0.3	8.6

est. = estimated value

NDA = No Data Available

**48 volt**

Gear Ratio	Max Load/Dynamic		Typical Speed/No Load		Typical Speed/Max Load	
	Lbs. [US]	Newtons	inches/sec	mm/sec	inches/sec	mm/sec
5:1	674 est.	3000 est.	3.2	80.1	2.4	60.5
10:1	1012	4500	NDA	NDA	NDA	NDA
20:1	1461	6500	0.8	20.6	0.7	17.7
30:1	1798	8000	0.6 est.	14 est.	0.4 est.	11 est.
40:1	2248	10000	0.4	9.9	0.35	8.9

est. = estimated value

NDA = No Data Available

Gear Ratio	Typical Current (A)					
	No Load			Full Load		
	12 VDC	24 VDC	48 VDC	12 VDC	24 VDC	48 VDC
5:1	2.7	1.5	0.8	28.7	15.3	7.7
10:1	2.9	2.5 est.	1.2 est.	25.0	13.5 est.	7.0 est.
20:1	2.5 est.	1.0	0.5	18.1 est.	8.0	4.1
30:1	NDA	NDA	NDA	NDA	NDA	NDA
40:1	1.9	1.0	0.4	13.0	6.7	3.3

est. = estimated value

NDA = No Data Available

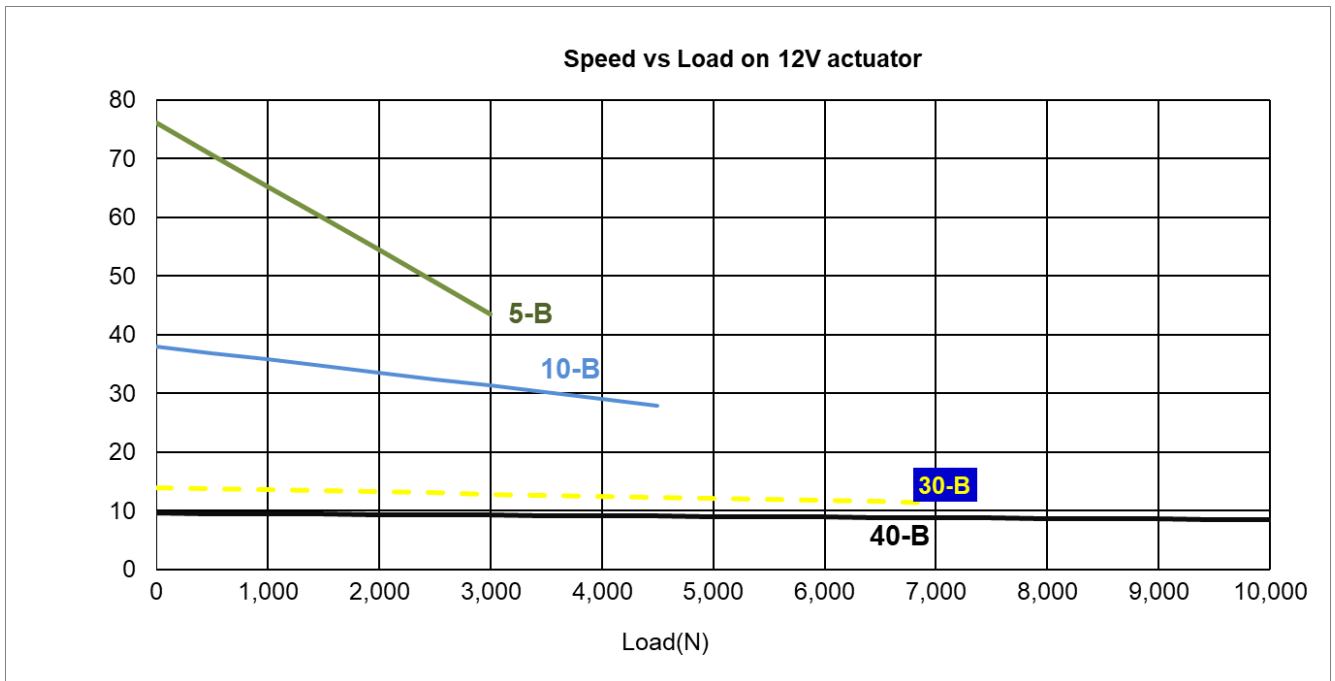
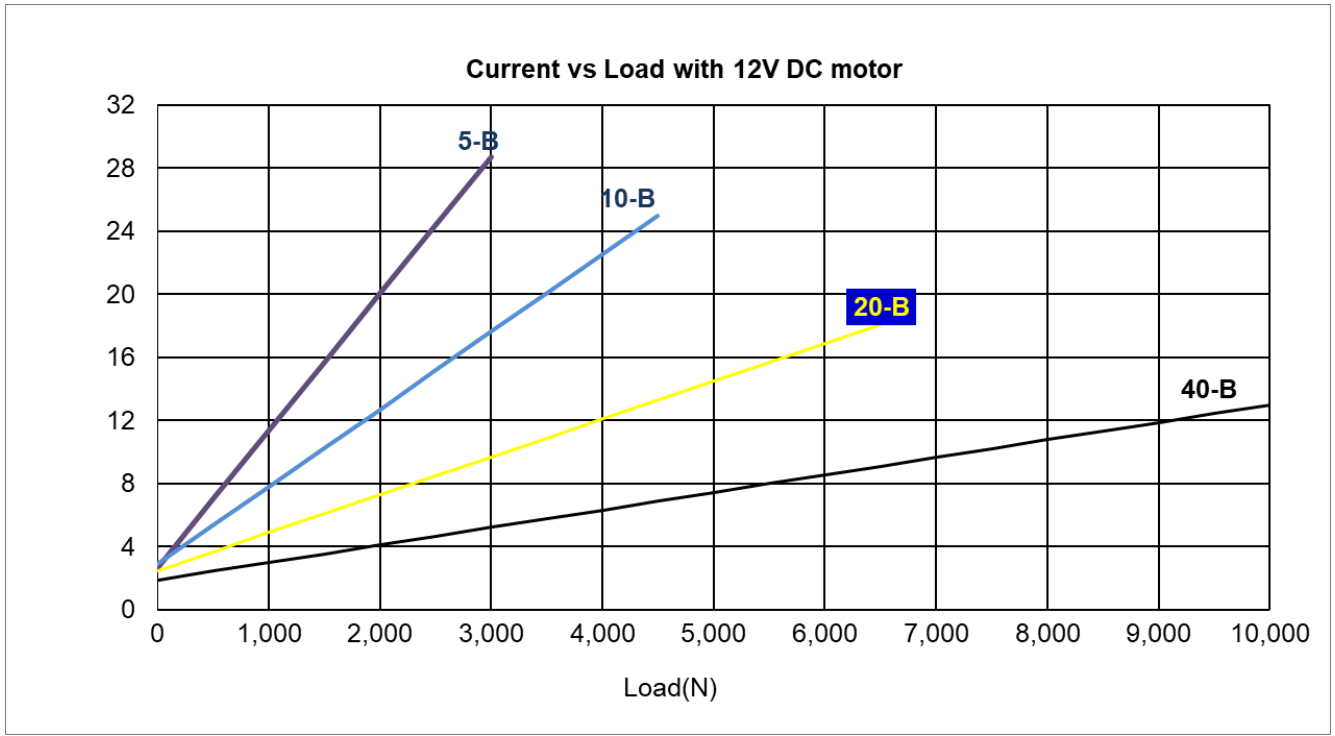

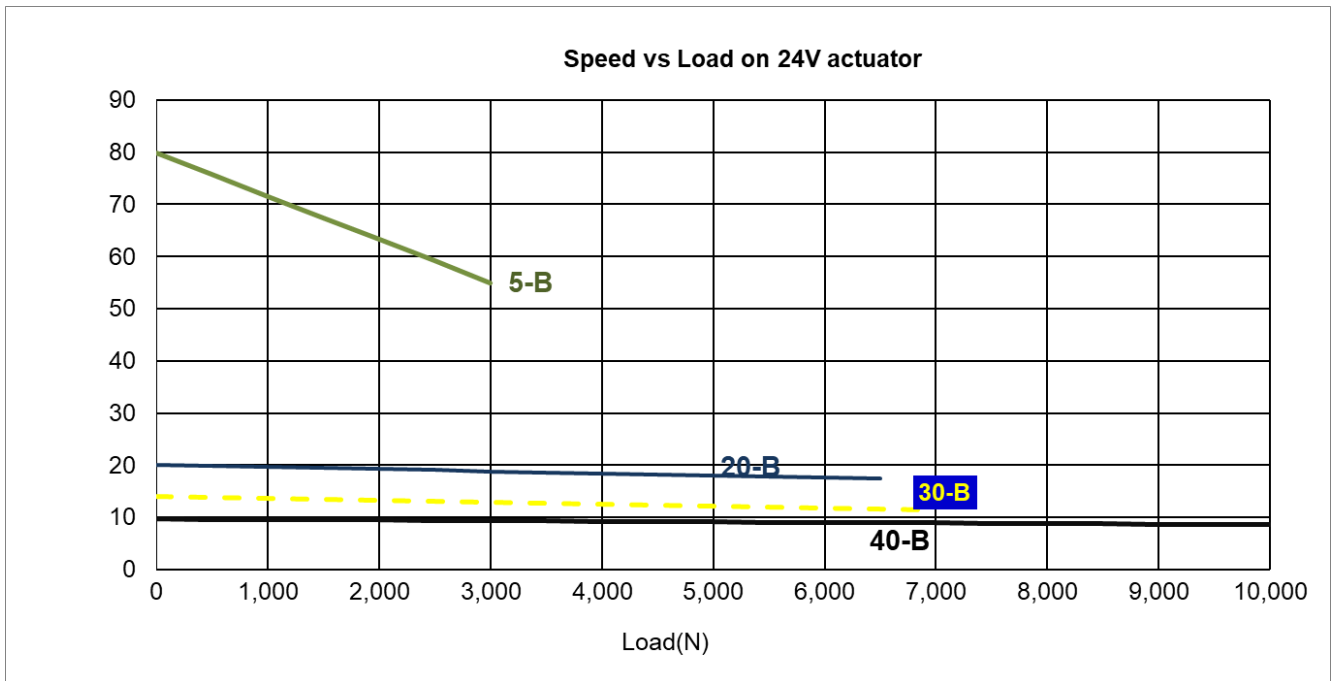
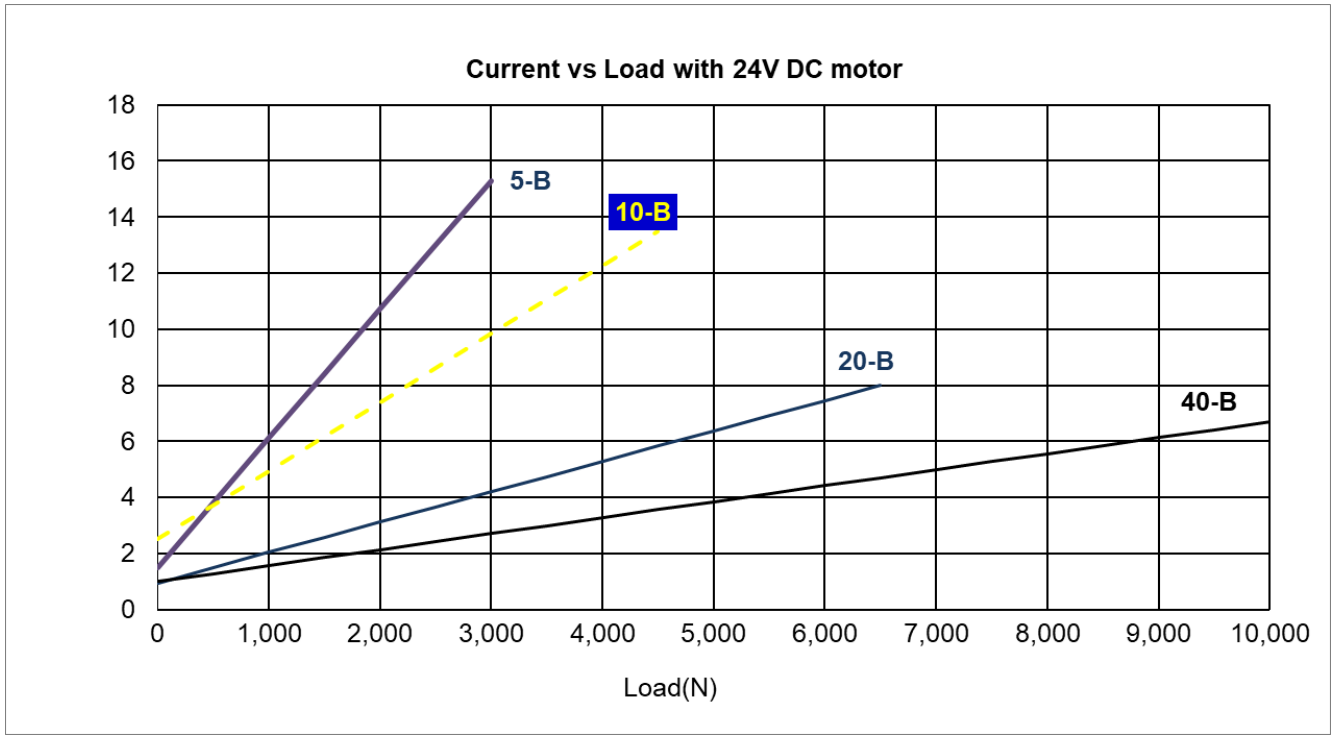



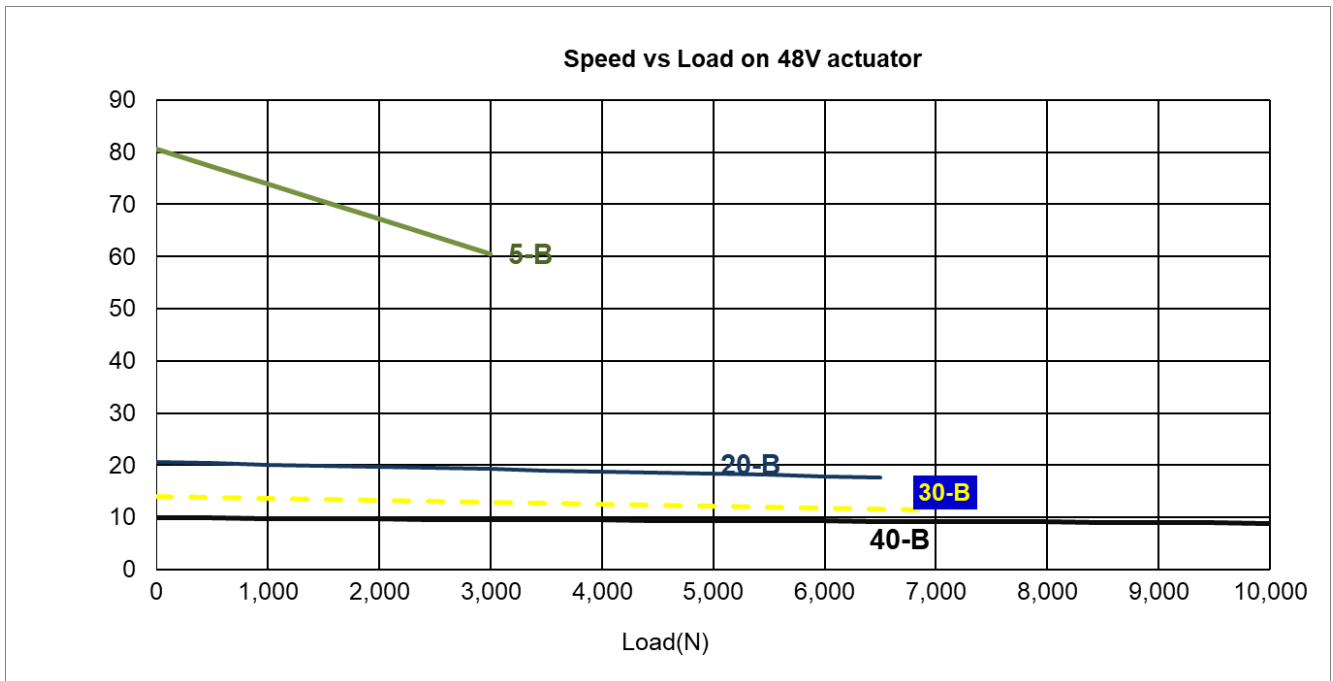
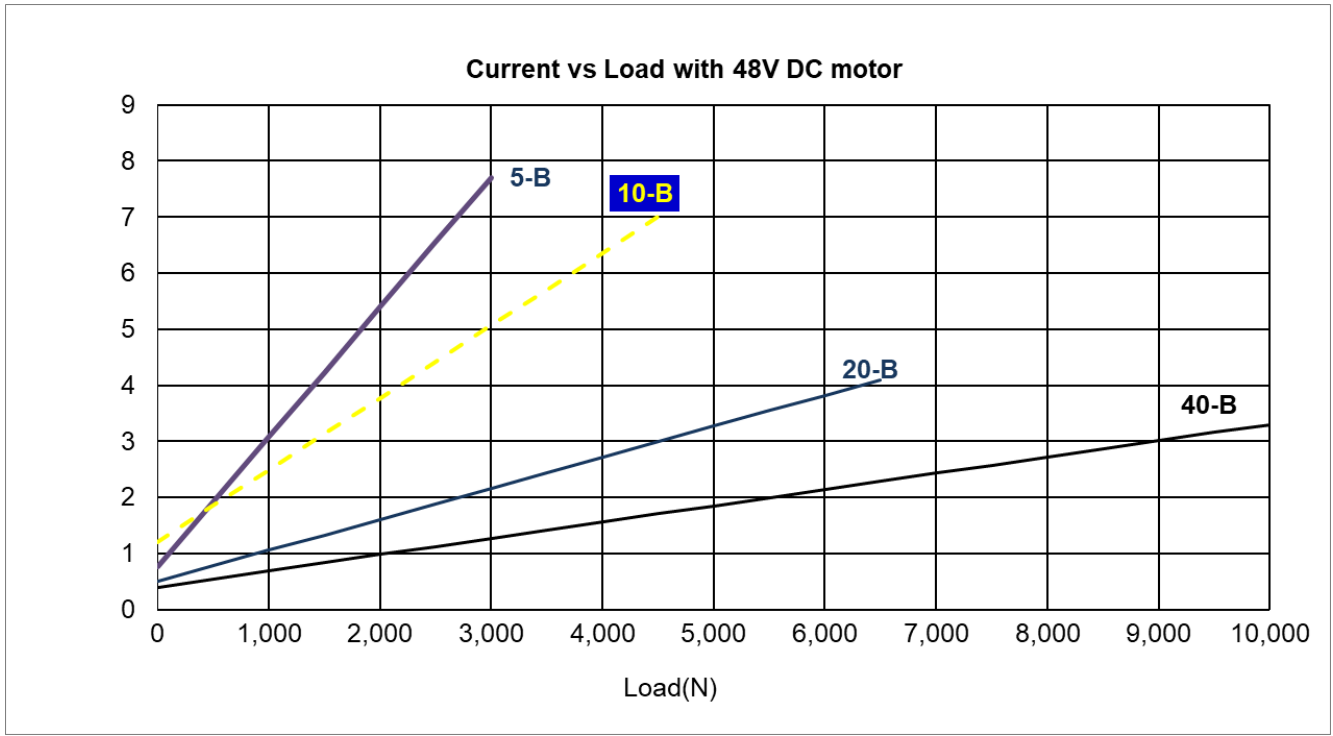

## Electrical

### Standard

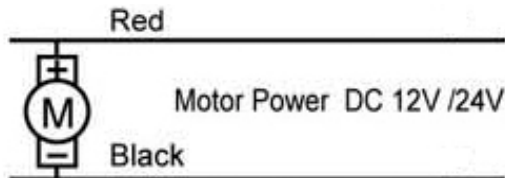

Gear Ratio: 5:1, 10:1, 20:1

Red + // Black - : Extend

Red - // Black + : Retract

Gear Ratio: 30:1, 40:1

Red + // Black - : Retract

Red - // Black + : Extend

### With Limit Switches

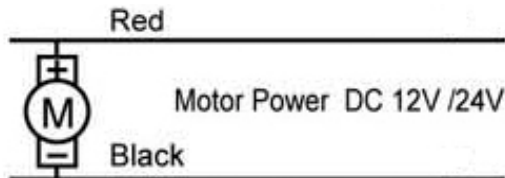

Gear Ratio: 5:1, 10:1, 20:1, 30:1, 40:1

Red + // Black - : Extend

Red - // Black + : Retract

### With Potentiometer (or Limit Switches and Potentiometer)

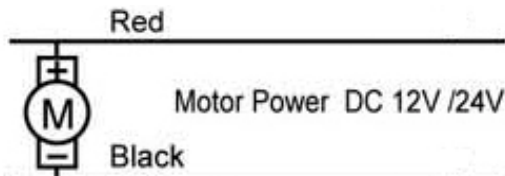

Gear Ratio: 5:1, 10:1, 20:1, 30:1, 40:1

Red + // Black - : Extend

Red - // Black + : Retract

## Potentiometer

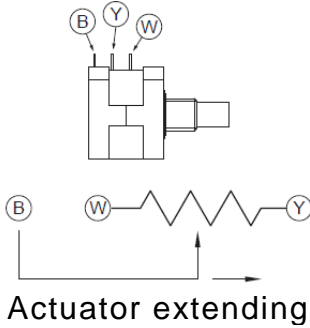

When fully retracted, the potentiometer reading will be in or near the range of 0 - 600Ω (between the blue and the white wires).

When fully extended, the potentiometer reading will be in or near the range of 8K - 10KΩ (between the blue and the white wires).

## Base Stud Mount Hole Orientation

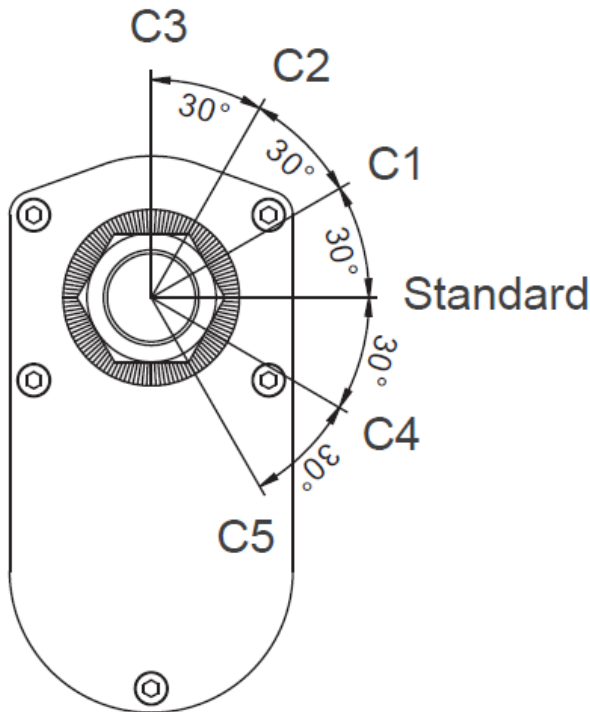

**Ordering Key**

GF17 -    -  -

**Input Voltage**

- 12 : 12 VDC
- 24 : 24 VDC
- 48 : 48 VDC (available by special order)

**Gear Ratio**

- 05 : 5:1
  - 10 : 10:1
  - 20 : 20:1
  - 30 : 30:1
  - 40 : 40:1
- Not all gear ratios stocked

**Stroke (nominal)**

- 04 : 4" [102mm]
  - 06 : 6" [153mm]
  - 08 : 8" [203mm]
  - 10 : 10" [254mm]
  - 12 : 12" [305mm]
  - 18 : 18" [457mm]
  - 24 : 24" [610mm]
- Additional stroke lengths available

**Options**

- 0 : None
- 1 : Limit Switches
- 2 : Potentiometer
- 3 : Potentiometer and Limit Switches

**IP Rating**

- 65 : IP65
- 69 : IP69K (available by special order)

- Not all combinations stocked

**Terms of Use**

The user is responsible for determining the suitability of Concentric International products for specific applications. Due to continuous development in order to improve its products, Concentric International products are subject to change without prior notice. Concentric International reserves the right to discontinue the sale of any products at any time.