

## 143 Series Seat Armrest Kit Installation Instructions

### Kit Contents

- (1) Left mounting bracket
- (1) Right mounting bracket
- (1) Left armrest pad
- (1) Right armrest pad
- (2) Armrest Stop setscrews
- (6) Hex Head screws
- (6) Clip-On nuts

### Tools Required

- Tape measure
- Drill with 1/8" drill bit
- Ratchet with 3/8" socket
- Flat blade screwdriver

### Assembly Procedure

1. Locate and mark the top hole on the Right side of the seat's plastic shell as shown in (Figure 1).
2. Drill a 1/8" diameter pilot hole in this location.

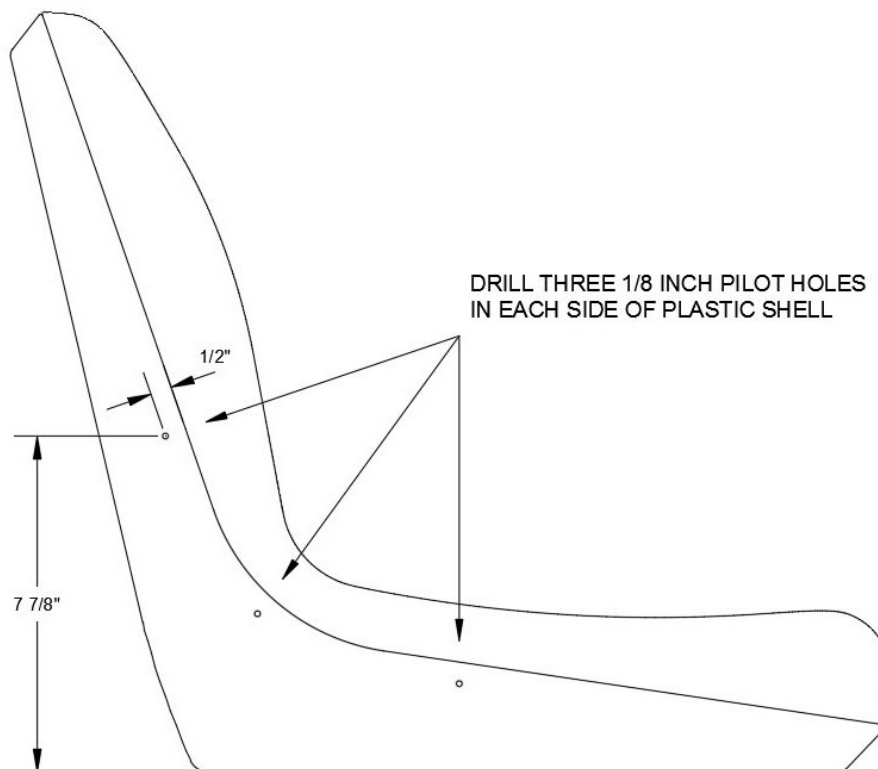

(Figure 1)

### 143 Series Seat Armrest Kit Installation Instructions

3. Slide a Clip-On nut over the hole, with the thread side inward.
4. Attach the upper hole of the Right mounting bracket (shown in Figure 2) to the plastic seat shell using a Hex Head screw. Do not tighten completely.
5. Rotate the mounting bracket into position to locate and mark the remaining two mounting holes. The holes should be  $1/2''$  from the plastic shell edge, similar to the upper hole.
6. Drill the two remaining  $1/8''$  pilot holes, and slide on the Clip-On nuts.
7. Secure the Right mounting bracket with two additional Hex Head screws, tightening all three.
8. Push the Right armrest pad onto the Right mounting bracket post. Refer to (Figure 2).

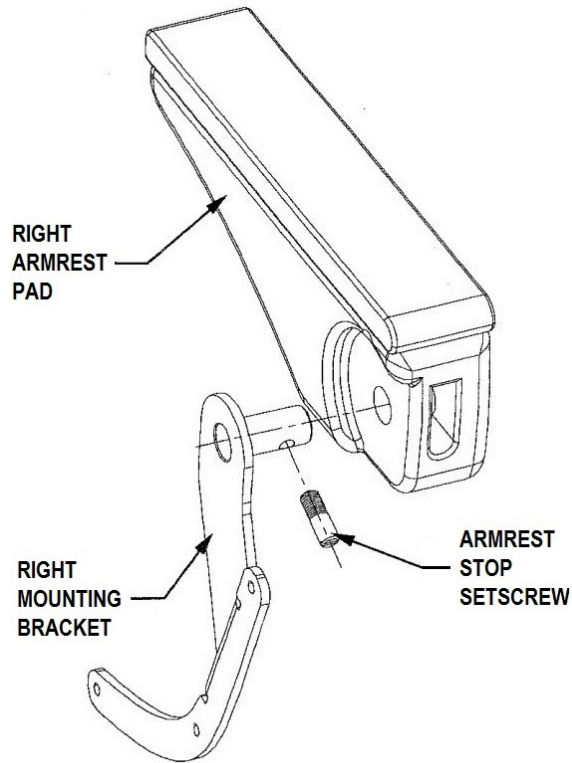

(Figure 2)

9. Pivot the armrest pad on the post to expose the Armrest Stop setscrew hole in the post, and install the Armrest Stop setscrew.
10. Repeat the installation procedure on the Left side of the seat.